

## AXO WORKMATE SERIES SHREDDERS

Superior technology including the industries most advanced electric motor control brings unrivalled benefits

- High throughput compared to other shredders with the same kW rating
- Low Energy Consumption
- Ease of maintenance
- Service back-up 24/7

## APPLICATIONS

Confidential document and product destruction, waste size reduction and plastic pre-granulation shredding are some of the common uses of AXO Shredding Machines. From in-house to contract Shredding Services, AXO is likely to have a model to suit your application.



WM408-08mm	WM608-16mm	WM832-16mm
15kW WM408-12mm	30kW WM608-38mm	74kW WM832-32mm
WM408-16mm	WM432-12mm	WM1020-30mm



LOW DUST



LOW NOISE



LOW POWER DEMAND

Many features set the AXO Workmate design apart from other shredders - simplicity, efficiency and reliability are some of them. Couple these with service of factory trained engineers for a total supply, installation and support package.



## PERFORMANCE

The cutter sequence, chamber size, shaft and knife geometry have been extensively tested and analysed to make the shredding process as efficient as possible

## AXO SHAFT DESIGN

Through being more robust than the shafts of hexagonal stacked shaft machines, the AXO one-piece design addresses shaft failures and the costs of new parts, lost production and business disruption. Many traditional shredders use knives stacked on a shaft, with torque nuts providing the stack tightness critical in supporting the shaft to protect against failure. The AXO one-piece cutter-shaft eliminates the need for torque nuts to provide this support, so reduces the incidence of shaft failure.

An AXO one piece shaft is so robust that AXO provide a guarantee against shaft breakages\*when shredding contaminants such as heavy steel items AXO's design ensures that impact is limited to the cutter area. The shaft itself will stay intact - this means a faster return to service than other designs.

## AXO SMOOTH-SHRED

All AXO Electric Shredders include "AXO Smooth-Shred" soft starter and current management technology. SmoothShred® was developed specifically for AXO by one of the worlds leading motor starter manufactures to lessen shock loads incurred when bringing electric shredders on-line, and to reduce the incidence of shaft reversal.

## POWER SUPPLY RESTRICTED?

In addition, through reducing current spikes, AXO's Smooth-Shred Technology and Dual Soft Starter System reduce the likelihood of problems being caused with power authorities. This means that if you have a low power supply capacity you may not be able to install a standard shredding machine, but you may be able to install an AXO Workmate.

## MORE TORQUE

Using planetary gearboxes driving each shaft independently we transmit more torque per shaft than other designs. This also saves weight, brings greater throughput and eliminates shaft failure common with gear intermeshed shaft designs.

## EASE OF SERVICE MAINTENANCE

AXO has incorporated access features with ease and speed of service in mind. We have focused on simplicity - we recognise that the people usually servicing the machines are Operators not Maintenance Engineers.

## CE COMPLIANT

All AXO equipment meets OSH requirements and are CE Certified

## NO SURPRISES

Some companies may accept a broken shaft - not AXO - our shafts are replaced only if the cutters are worn or suffered damage, at a time suitable to the customer and programmed into production. There are no sudden surprises! Often the main cost of replacing broken shafts is not the parts, but the labour and the time your machine is inoperable. AXO one piece shafts are quick and simple to replace compared with competitor machines.

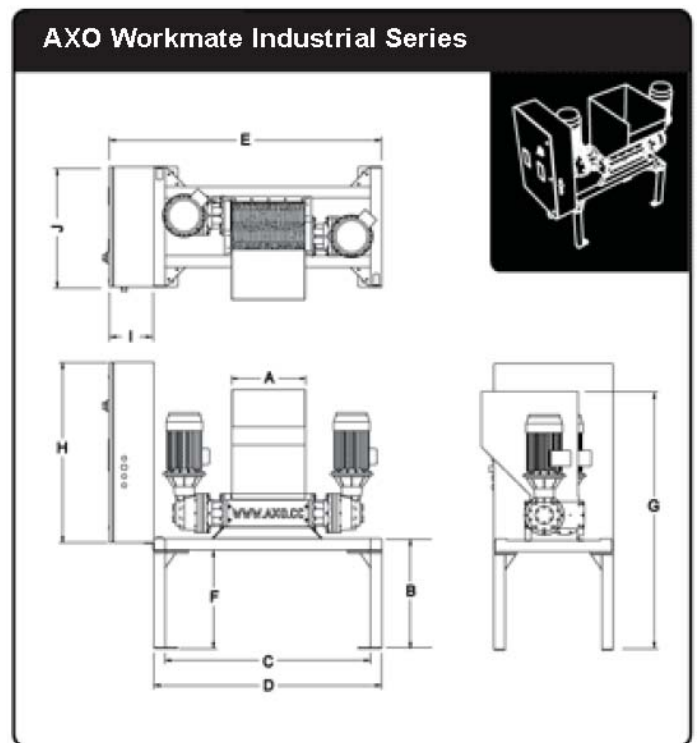

## DIMENSIONS (mm)

Model	A	B	C	D	E	F	G	H	I	J	kW	Cutter Width	Weight	Throughput Rate**
WM408E	408	860	1350	1450	1700	760	1632.5	1200	250	600	2x7.5	8/12/16mm	900 kg	800 kg/hr - 1200 kg/hr
WM432E	432	730	1380	1530	2010	655	1800	1200	300	800	2x15	12mm	1020 kg	Up to 2000kg/hr
WM608E	608	730	1380	1530	2010	655	1800	1200	300	800	2x15	16mm / 38mm	1200 kg	Up to 2500 / 3500 kg/h
WM832E	832	944	1750	2000	2500	810	2200	1200	300	800	2x37.5	16mm / 32mm	2500 kg	Up to 4000 / 6000 kg/hr
WM1020E	1020	944	1626	2000	2500	810	2350	1200	300	800	2x37.5	30mm	2750 kg	Up to 8000 kg/hr

\* When shredding waste office paper

\*\* Throughput figures vary according to feed method product type being shredded and other processing equipment. AXO Shredders Ltd does not guarantee throughput rates at any particular plant. Throughput figures shown are based on actual throughput rates achieved in the field however variable factors mean these rates cannot always be sustained.